



Electrolux

Modular Cooking Range Line 900XP Full Module Electric Fry Top, Chromium Plated

ITEM # _____

MODEL # _____

NAME # _____

SIS # _____

AIA # _____



Electrolux

900XP Full Module Electric Fry Top, Chromium Plated
Modular Cooking Range Line



391073 - 391176 - 391074 - 391177

Short Form Specification

Item No. _____

Unit to be Electrolux 900XP Full Module Electric Fry Top. Unit to have ___smooth or ___ 2/3 smooth and 1/3 ribbed cooking surface. Cooking surface to be of chromium-plated mild steel. Electric characteristics to be ___ 400 V or ___ 230 V three phase. Unit to be installed on open base installations, bridging supports or cantilever systems. Unit to feature a collector on bottom the cooking surface for the collection of grease and fat. Body and work top of unit entirely in Stainless steel with Scotch Brite finish. Extra strength work top in heavy duty 2 mm Stainless steel. Unit has right-angled side edges to allow flush-fitting junction between units.

Main Features

- Unit to be mounted on open base cupboards, bridging supports or cantilever systems.
- Cooking surface in 15mm thick chromium-plated mild steel for optimum grilling results.
- Large drain hole on cooking surface permits the draining of fat into large 1 liter collector placed under the cooking surface.
- Electric elements in incoloy positioned under the cooking plate.
- Safety thermostat and thermostatic control.
- Units have separate controls for each half module of the cooking surface.
- Stainless steel high splash guards on the rear and sides of cooking surface. Splash guards can be easily removed for cleaning and are dishwasher-safe.
- The special design of the control knob system guarantees against water infiltration.
- IPX5 water protection.

Construction

- Cooking surface to be completely smooth or 2/3 smooth and 1/3 ribbed.
- Unit is 930 mm deep to give a larger working surface area.
- All exterior panels in Stainless Steel with Scotch Brite finishing.
- AISI 304 stainless steel worktop, 2mm thick.
- Model has right-angled side edges to allow flush fitting joints between units, eliminating gaps and possible dirt traps.

Optional Accessories

- Scraper for smooth plate fry tops PNC 164255
- Junction sealing kit PNC 206086
- Support for bridge type installation, 800mm PNC 206137
- Support for bridge type installation, 1000mm PNC 206138
- Support for bridge type installation, 1200mm PNC 206139
- Support for bridge type installation, 1400mm PNC 206140
- Support for bridge type installation, 1600mm PNC 206141
- Chimney upstand, 800mm (only for 391074) PNC 206304
- - NOT TRANSLATED - PNC 206308
- - NOT TRANSLATED - PNC 206309
- Grease/oil kit container for 700 line frytops (half and module) and 900 line frytops (module) PNC 206346
- Chimney grid net, 400mm (700XP/900) PNC 206400

APPROVAL: _____



Electrolux

**Modular Cooking Range Line
900XP Full Module Electric Fry Top,
Chromium Plated**

- Scraper for ribbed plate fry tops - kit includes knife blades for both smooth and ribbed surface (only for 391074, 391177) PNC 206420
□
- Side handrail-right/left hand (900XP) PNC 216044
□
- Frontal handrail, 800mm PNC 216047
□
- Frontal handrail, 1200mm PNC 216049
□
- Frontal handrail, 1600mm PNC 216050
□
- Water drain for full module fry tops PNC 216153 □
- Large handrail - portioning shelf, 800mm PNC 216186 □
- 2 side covering panels for top appliances PNC 216278
□

**Modular Cooking Range Line
900XP Full Module Electric Fry Top, Chromium Plated**

The company reserves the right to make modifications to the products without prior notice. All information correct at time of printing.

2018.10.03

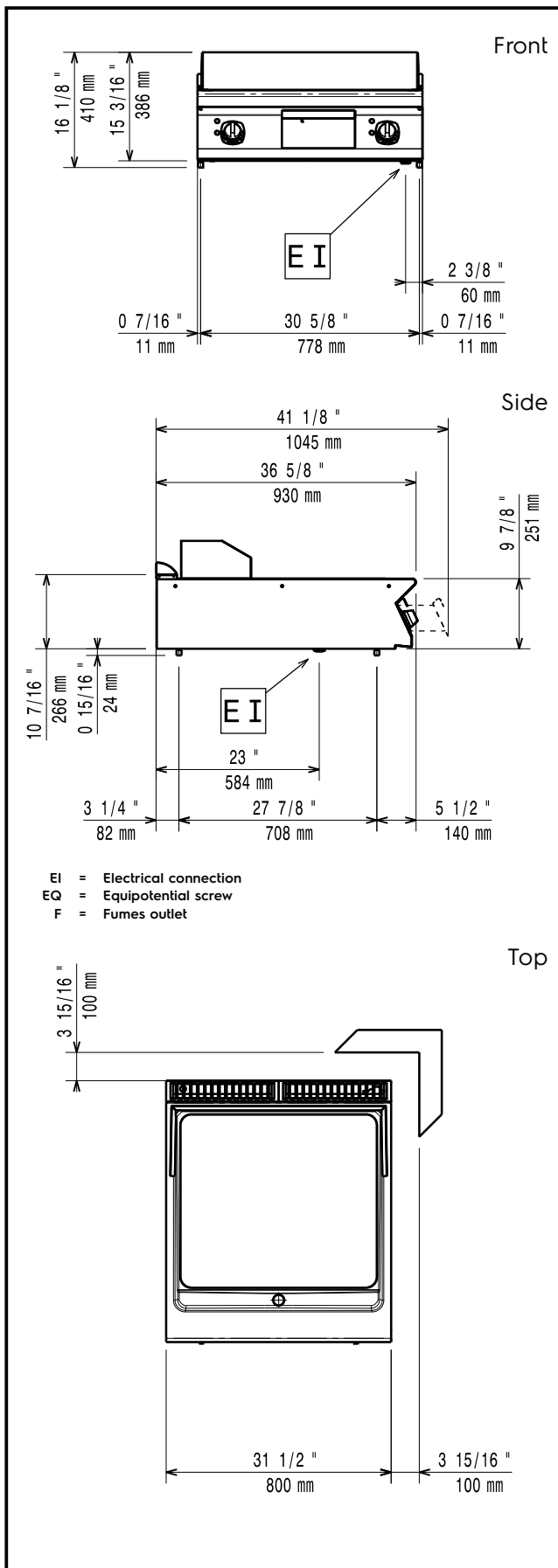

Electric

Supply voltage:

391073 (E9FTEHCS00)	380-400 V/3 ph/50/60 Hz
391176 (E9FTEHCS0N)	230 V/3 ph/50/60 Hz
391074 (E9FTEHCP00)	380-400 V/3 ph/50/60 Hz
391177 (E9FTEHCP0N)	230 V/3 ph/50/60 Hz

Electrical power, max:

15 kW

Total Watts:

15 kW

Gas

Natural gas - Pressure:

391073 (E9FTEHCS00)	7" w.c. (17.4 mbar)
---------------------	---------------------

LPG Gas Pressure:

391073 (E9FTEHCS00)	11" w.c. (27.7 mbar)
---------------------	----------------------

Key Information:

Cooking surface width: 730 mm

Cooking surface depth: 700 mm

Working Temperature MIN: 120 °C

Working Temperature MAX: 280 °C

Net weight:

391073 (E9FTEHCS00)	90.5 kg
391176 (E9FTEHCS0N)	105 kg
391074 (E9FTEHCP00)	88 kg
391177 (E9FTEHCP0N)	105 kg

Shipping weight:

391073 (E9FTEHCS00)	101.5 kg
391176 (E9FTEHCS0N)	120 kg
391074 (E9FTEHCP00)	99 kg
391177 (E9FTEHCP0N)	120 kg

Shipping height:

391073 (E9FTEHCS00)	560 mm
391176 (E9FTEHCS0N)	540 mm
391074 (E9FTEHCP00)	540 mm
391177 (E9FTEHCP0N)	540 mm

Shipping width:

391073 (E9FTEHCS00)	1010 mm
391176 (E9FTEHCS0N)	900 mm
391074 (E9FTEHCP00)	1020 mm
391177 (E9FTEHCP0N)	1020 mm

Shipping depth:

391073 (E9FTEHCS00)	860 mm
391176 (E9FTEHCS0N)	1020 mm
391074 (E9FTEHCP00)	860 mm
391177 (E9FTEHCP0N)	860 mm

Shipping volume:

391073 (E9FTEHCS00)	0.49 m ³
391176 (E9FTEHCS0N)	0.5 m ³
391074 (E9FTEHCP00)	0.47 m ³
391177 (E9FTEHCP0N)	0.5 m ³

If appliance is set up or next to or against temperature sensitive furniture or similar, a safety gap of approximately 150 mm should be maintained or some form of heat insulation fitted.